

CONTURBEX

The worm/screen centrifuge



State-of-the-art centrifuge design
developed from decades
of experience

Introduction

Continuous filtration technology is where Siebtechnik centrifuges offer the greatest benefits from experience. In 1938, the first vertical continuous Siebtechnik worm/screen centrifuges were developed for industrial applications with a diameter of 1,000 mm.

Under the product name CONTURBEX, the first horizontal worm/screen centrifuge was supplied by Siebtechnik in 1948. The CONTURBEX quickly became a global term for separation technology and centrifuge construction principle. This machine design has developed into a very versatile screening centrifuge for a wide variety of separation requirements.

Today, several thousand Siebtechnik CONTURBEX centrifuges are operating worldwide in the chemical, bulk goods processing, food products and environmental industries.



The solids/liquids separation principle CONTURBEX

The worm/screen centrifuge is composed of a drive unit located in a bearing housing, the screen retaining basket, the screen element, the transport worm and the product housing enclosing the rotating parts. The solids/liquid mixture flows into the machine via a central feed pipe to the inside of the worm. The interior of the worm has a feed cone that preaccelerates the slurry and also distributes it uniformly onto the screening element inside the rotating basket.

The screen basket and screen element are normally of conical design to meet the process requirements.

Inside the basket and screen is a concentrically located worm where the flight tips are set at a clearance of 0.5 - 4 mm from the screen surface.

These components make up the rotating wetted parts which are of single bearing design cantilevered from the drive housing. The worm rotates at a slightly different speed than the screen basket which results in uniform product acceleration and distribution. This makes the machine very insensitive to fluctuations in the feed concentration and other operating conditions.

The solids/liquid mixture enters the rotating components in the area of the smallest diameter and the majority of liquid is separated through the screen. In this area the circumferential speed is lowest resulting in smaller power demand compared to cylindrical design machines for the same purpose.

Most solids will slide toward the largest diameter under the influence of centrifugal force, where they are discharged into the product housing over the open basket end. If the solids try to stick to the screening surface, the worm pushes them forward and if the solids try to slide out too quickly, the worm holds them inside the basket.

The transport worm acts as a control mechanism by regulating the solids' sliding speed and retention time. If the coefficient of friction of the wet solids is low, the flights hold the solids back, and near the discharge end of the screen basket if the dewatered solids friction force is high against the screen, the worm will advance the solids to discharge.

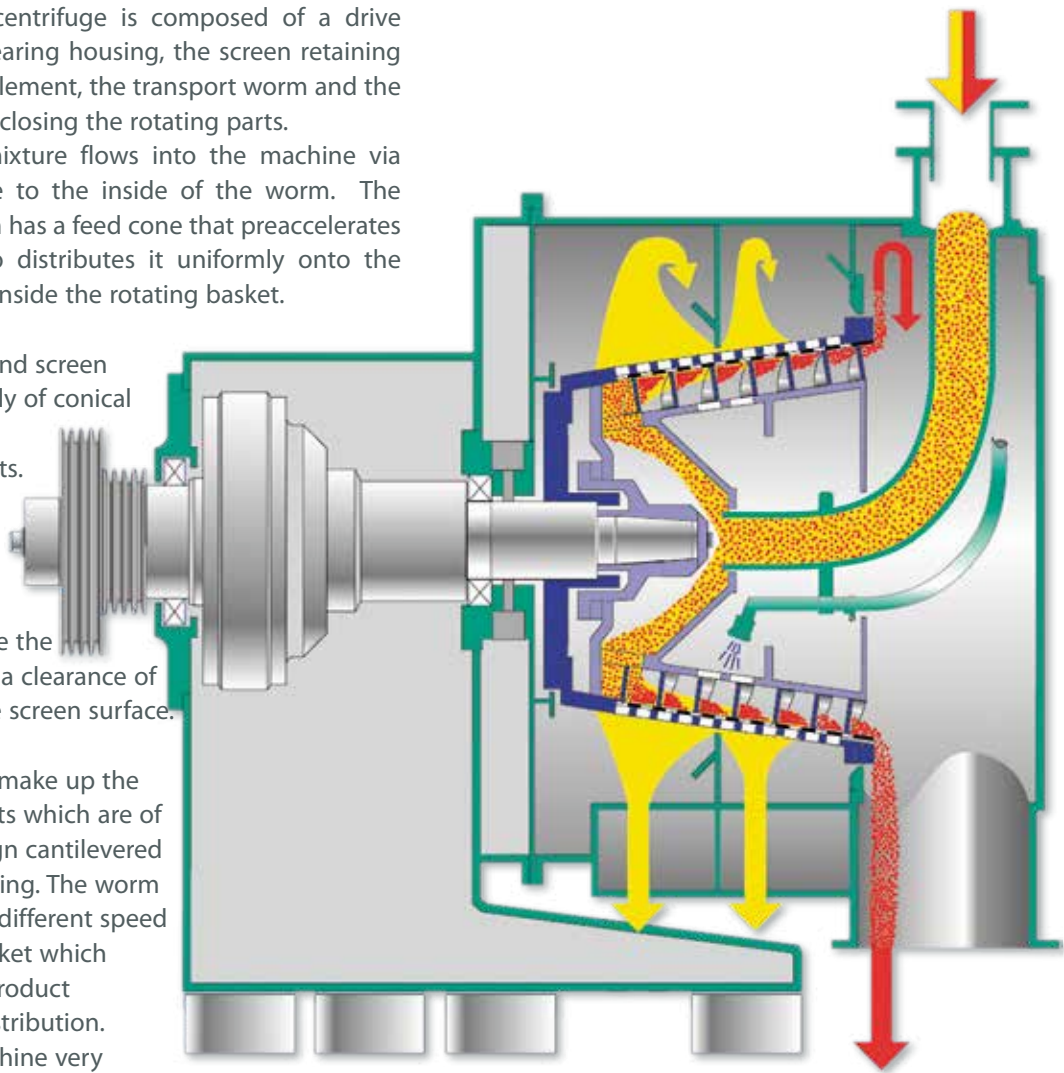

The transport power required for this is relatively low based on the machine design and experience.

Another advantage of the worm/screen centrifuge is the way the solids are handled on the screening element. The Conturbex operates via thin cake filtration, i.e. no dense, hard solids layer inside the basket. Due to the conical basket design, the solids layer thickness reduces as it progresses toward the larger diameter which loosens the "cake" allowing further dewatering. It also allows the removal of fine impurities via a displacement wash through the thinning solids layer near the discharge end of the basket.

However, important choices for successful operation and performance are the correct selection of the screening element and the operating parameters for the machine. This is based on existing experience or through pilot scale tests.

The construction principle CONTURBEX

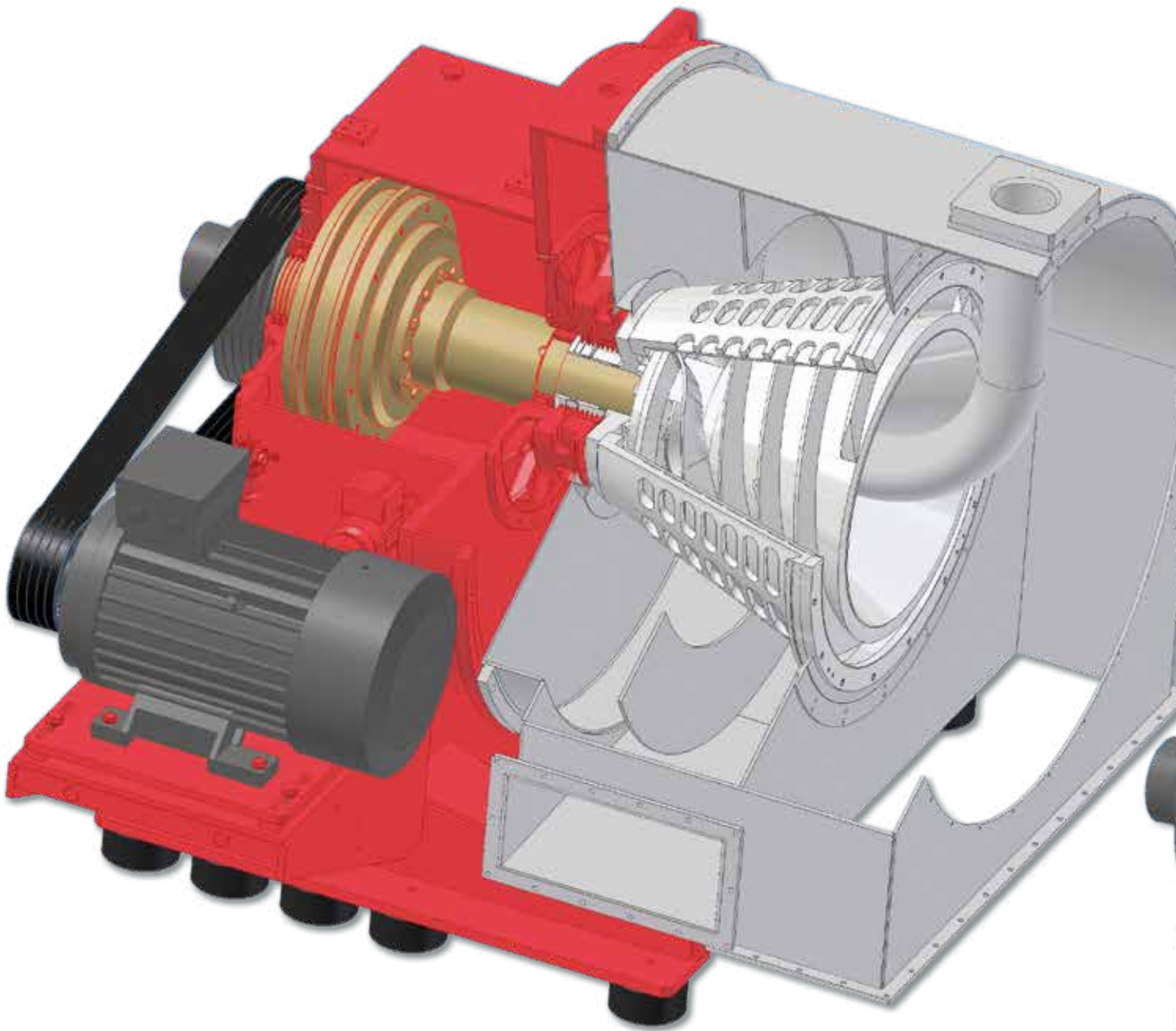

While there is a general tendency towards standardization, Siebtechnik focuses on detailed, application-related design. Our application specialists and engineers design and build the unit based on the process/product and customer requirements. The construction principle of the worm/screen centrifuge is based on a proven basic design, where the geometry of the rotating parts and the operating parameters are adjusted to the particular separation requirements.

In the traditional construction principle, the complete rotating assembly is incorporated into a heavy duty bearing housing.

Here the screen basket and the worm are cantilevered into the product collection housing. This single bearing overhung design allows for distinct separation of the drive and the process sides of the machine.

At the same time, the bearing housing has the function of a machine basic frame and contains the machine's lubrication reservoir and supply. The product housing is also cantilevered from a large front flange. The bearing housing is the main carrying element of the entire machine.

Vibration isolation of the bearing housing from the foundation or the structural steel support is done with rubber buffers. These eliminate 95% of any/all dynamic loads which would be transmitted to the support structure.

The rotating components consist of the drive section installed in the bearing housing including the gear unit and the process rotating parts projecting into the pro-

duct housing, consisting of the screen basket, screen insert and transport worm.

The rotor is V-belt driven by the main motor located on the side of the common base frame. The robust gear ensures predetermined differential speed between the drum and worm and results in uniform transport of solids.

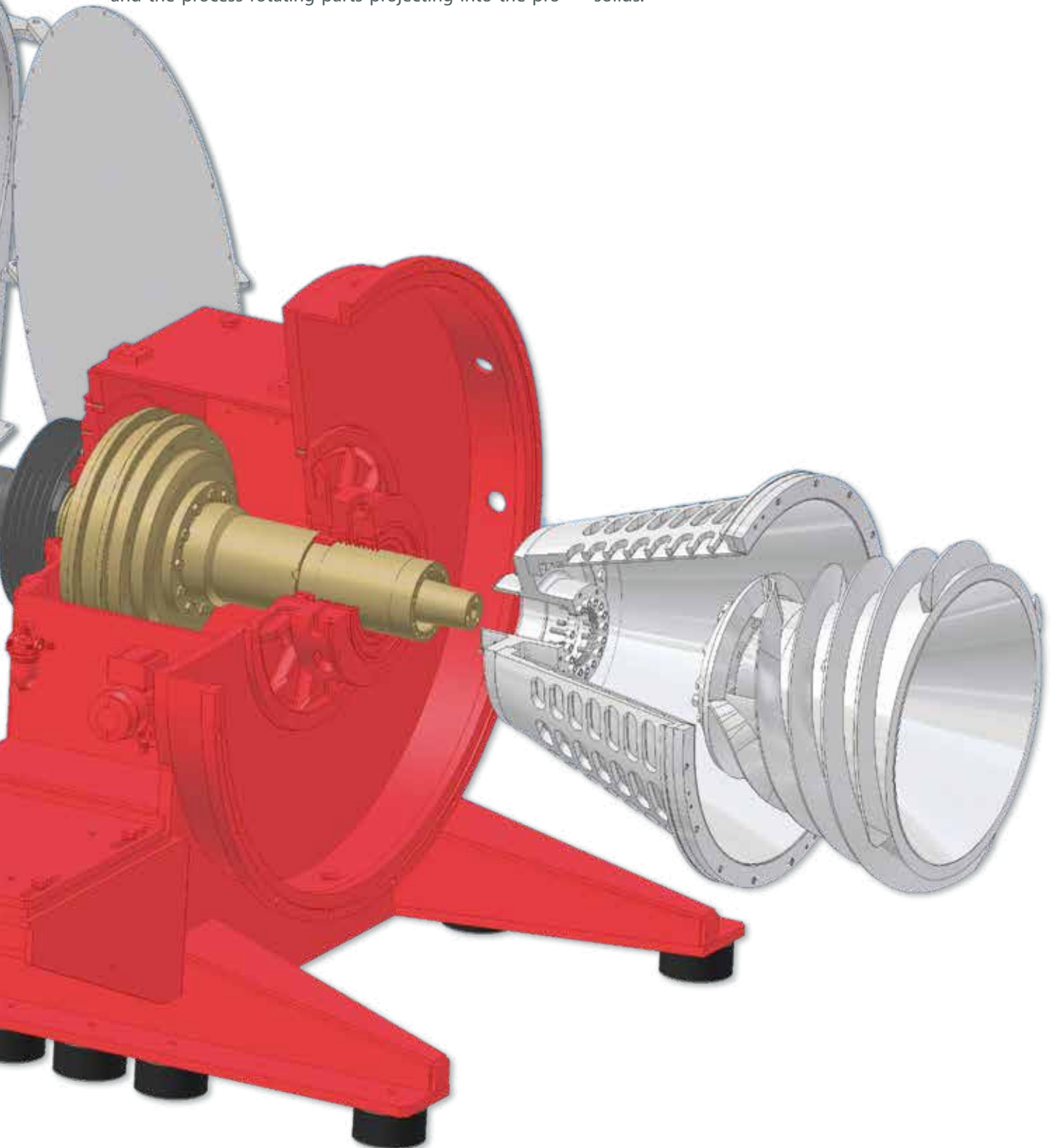

The "CX Series" construction principle CONTURBEX

With nearly 60 years experience building these worm/screen centrifuges for a wide variety of processes and applications, a new generation CONTURBEX has been developed. Using contemporary design construction and manufacturing methods, the new designation "CX Series" offers economic benefits to operation and maintenance, in addition to larger machine sizes and greater throughput capacity.

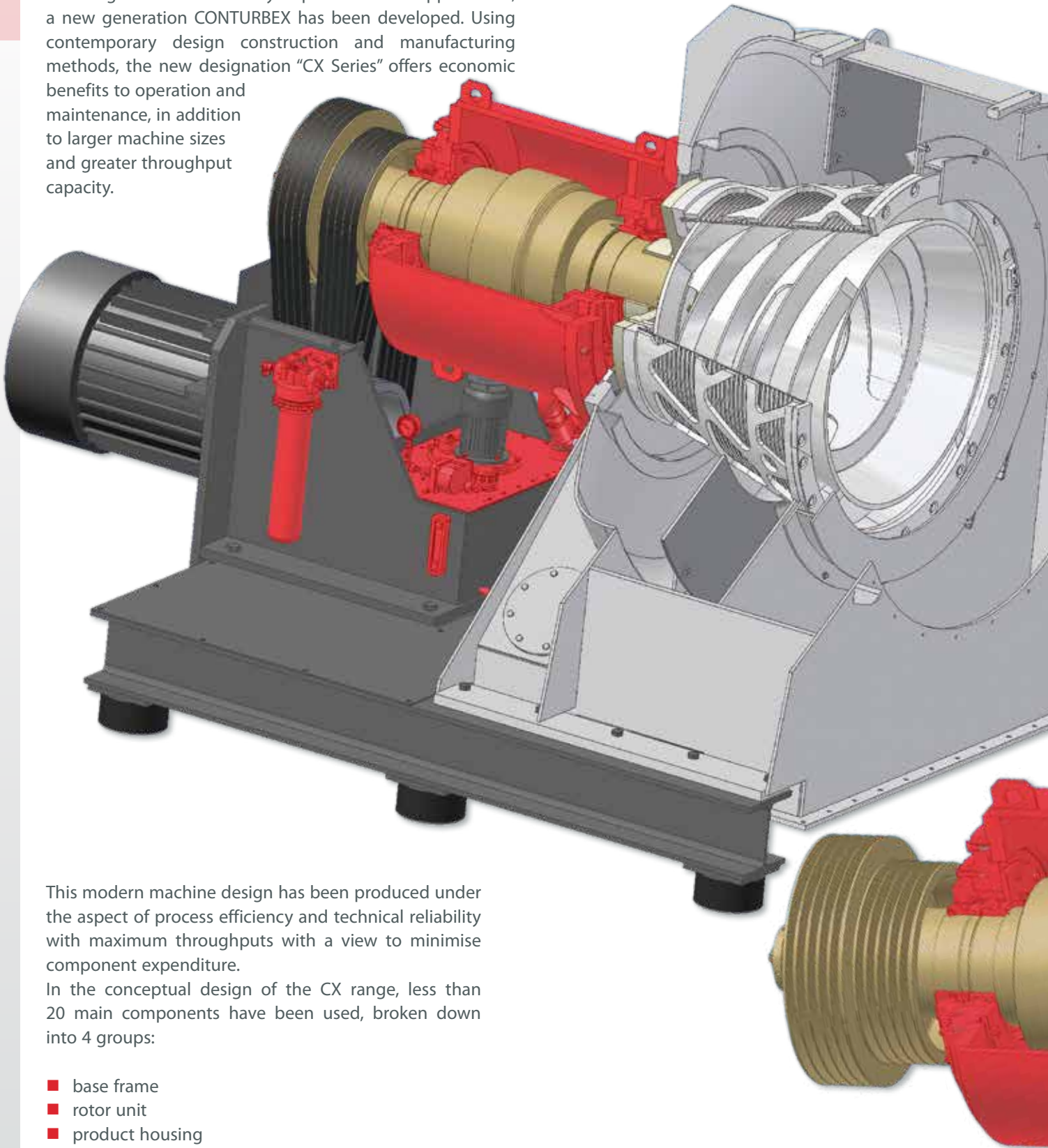

This modern machine design has been produced under the aspect of process efficiency and technical reliability with maximum throughputs with a view to minimise component expenditure.

In the conceptual design of the CX range, less than 20 main components have been used, broken down into 4 groups:

- base frame
- rotor unit
- product housing
- oil supply

The "CX Series" basic design

The rotor's simplified bearing is self-centering within the tubular bearing housing and independent of the product housing. This yields a guaranteed centering axis and resulting optimal running behavior.

This simplified bearing design allows maximum assembly access, which brings about lower cost spare components.

The ability to quickly exchange pre-assembled rotor assemblies or individual wear parts, reduces downtime and loss of production.

Despite a reduction in components, the mass of the machine and properly positioned center of gravity ensure quiet and low-vibration operation of this design.

The gear and all bearings are connected to a single external oil supply system and are continuously lubricated via a circulating flow.

This guarantees optimum lubrication even for low temperature applications and extends the lifetime to a maximum level with minimal maintenance or expense.

The robust gear designs utilize short and strong drive shafts which produce high output torque. The drives are reliably and effectively protected against overload by a patented disengaging coupling.

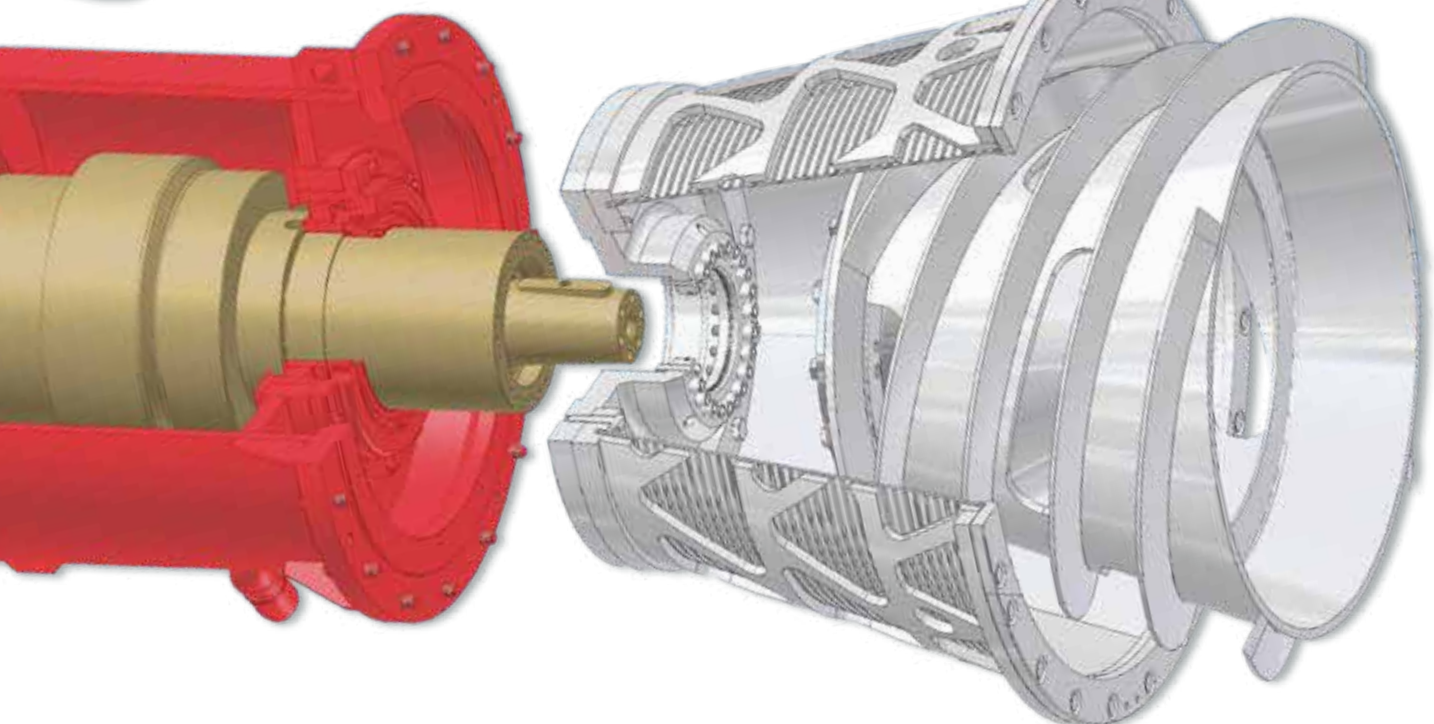
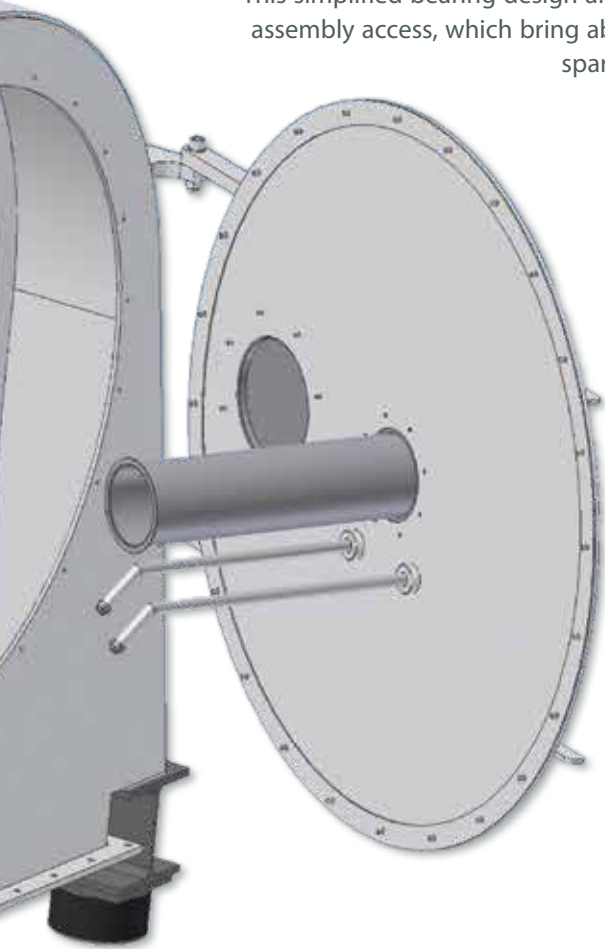

Standard - CONTURBEX available executions

Type		H 200	H 250	H 320	H 350	H 400	H 450	H 520	H 600	H 700	H 900	H 1000
Drive motor	approx. kW	3.0	5.5	7,5	11	15	22	30	37	55	75	90
Length	mm	700	910	940	1150	1150	1150	1480	1560	2150	2400	2600
Width	mm	880	1050	1165	1500	1500	1500	1920	2000	2100	2600	2700
Height	mm	570	800	950	970	1150	1150	1470	1470	1650	2600	2600
Weight	kg	230	560	700	900	1000	1100	1800	2000	4000	7000	8000

We reserve the right to make changes which serve technical progress.



CX - CONTURBEX available executions

Execution size Type		II CX			III CX			IV CX		
Drum Diameter	mm	600	700	800	900	1000	1100	1200	1300	1500
Drive motor	approx. kW	45	55	75	90	90	110	110	137	250
Length	mm	approx. 2000			approx. 3000			approx. 4200		
Width	mm	approx. 2000			approx. 2400			approx. 2760		
Height	mm	approx. 1700			approx. 2300			approx. 2600		
Weight	kg	approx. 4000			approx. 8000			approx. 13000		

We reserve the right to make changes which serve technical progress.

The "CX Series"



CONTURBEX CX 1500

CONTURBEX - successfully used for _____

Adipic Acid
AH-Salt
Amino Acetic Acid
Ammonium Persulphate
Ammonium Phosphate
Ammonium Sulphate
Ammonium Thiosulphate
Anthracene
Aspirin
Bisphenol
Borax
Calcium Formiate
Carboxy-Methylcellulose
Celluloid Wool
Cellulose Wool
Chocolates (broken)
Citric Acid
Coal Slurry
Coffee Freeze Concentrate
Coffee Grounds
Copper Sulphate
Cotton Linters
Crystal Soda
Date Stones

Dimethylterephthalate
= DMT from Methanol
Dipterex
Disodium Phosphate
Finely chopped onions
Fungal Mycel
Glacial Acetic Acid
Glauber Salt
Greaves
Gypsum
Hops frome
Methylene Chloride
Ion Exchange Resin
Ironsulphate Heptahydrate
Lactose
Manganese Sulphate
Methylcellulose
Monosodiumphosphate
Naphionate
Nuts (broken)
Nylon Chips
Oxalic Acid
Patent Soda
Pearl Polymerisate

Pentaerythrite
Plastic Granules
Plexiglas Beads
Polyethylene
Polymethacrylate
Polystyrene
Polyvinylalcohol
Potash
Potash Alum
Potash Solvent Residue
Potassium Bicarbonate
Potassium Bichromate
Potassium chloride
Potassium Monochromate
Potassium Pensulphate
Potassium Phosphate
Potassium Sulphate
PVA
PVC
Pyrazolene
Rock Salt
Rubber Regenerate
Silver Nitrate
Sodium Acetate

Sodium Bisulphite
Sodium Carbonate
Sodium Chlorate
Sodium Chloride
Sodium Formiate
Sodium Gluconate
Sodium Metaborate
Sodium Nitrate
Sodium Nitre
Sodium Perborate
Sodium Phosphate
Sodium Sulphate
Sodium Sulphite
Sodium Tetraborate
Sodium Thiosulphate
Tartaric Acid
Tin Sulphate
Trisodium Phosphate
Vegetables
Vegetable Extracts
Zinc Sulphate

and many others



General CONTURBEX design variations

Building a machine for a specific product or application is based on many variables, in addition to gas-tight or explosion-proof designs.

Screen basket geometry based on product:

- 0° cylindrical execution
- 10° drum inclination
- 15° drum inclination
- 20° drum inclination

Different screen executions:

- Slotted screen inserts
- CONIDUR® - screen plate inserts
- Laser-cut screen plate inserts

There are three possible variations for drive execution:

- Cyclo gear unit
- Siebtechnik planetary gearing
- Hydraulic drive (variable worm speed)

With all rigid gear executions, machines can be supplied with dual drive motors to control differential speeds via variable frequency drives.

Centrifuge housing seals in accordance with the production process and are standardized in the following executions:

- Open labyrinth sealing
- chamber packing for vapor-tight execution
- PTFE chamber packing for gas-tight execution
- Pressure-tight execution with slip ring seals

Additional special accessories or designs:

- Filtrate discharge via cyclone with or without vent recirculation
- Solids discharge via collecting ring
- Product feed via screw conveyor
- Product washing unit
- Separate wash liquid discharge
- Food-grade design

Material executions

All process contact parts can be manufactured in corrosion-resistant, austenitic steels, Hastelloy, nickel, titanium, etc. depending on the particular application. Machines for the coal and sand industry are typically carbon steel construction. In all applications, proper wear protection is available for abrasive feed material.

CIP – cleaning

Our CONTURBEX centrifuges are equipped with standard spray nozzles, so the machines are self-cleaning without additional expense.

For special requirements, the centrifuge can be provided with a CIP cleaning system. Included are special washing tubes, nozzles and if necessary, a slow speed drive to allow flooding of the product contact parts.

ATEX execution for application in EX protective zones

Pursuant to EU directives 94/9/EG (ATEX 100a), all Siebtechnik centrifuges can be provided with an ATEX package corresponding to the hazard zones.



Delivery Program

Screening Machines & Process Equipment

Circular- and elliptical-motion screening machines
Linear-motion screening machines
Banana and excenter screening machines
Multi-deck screening machines
Tumbler screening machines
Jigs and channel conveyors

Sampling, Crusher & Laboratory Equipment

Individual units and complete installations for sample taking and preparation
Pneumatic tube systems
Comminution equipment
Control screening machines
Laboratory equipment
Automation solutions

Centrifuges

Screen worm centrifuges
Pusher centrifuges
Sliding centrifuges
Vibrating centrifuges
Decanter centrifuges
Screen decanter centrifuges
Laboratory centrifuges