

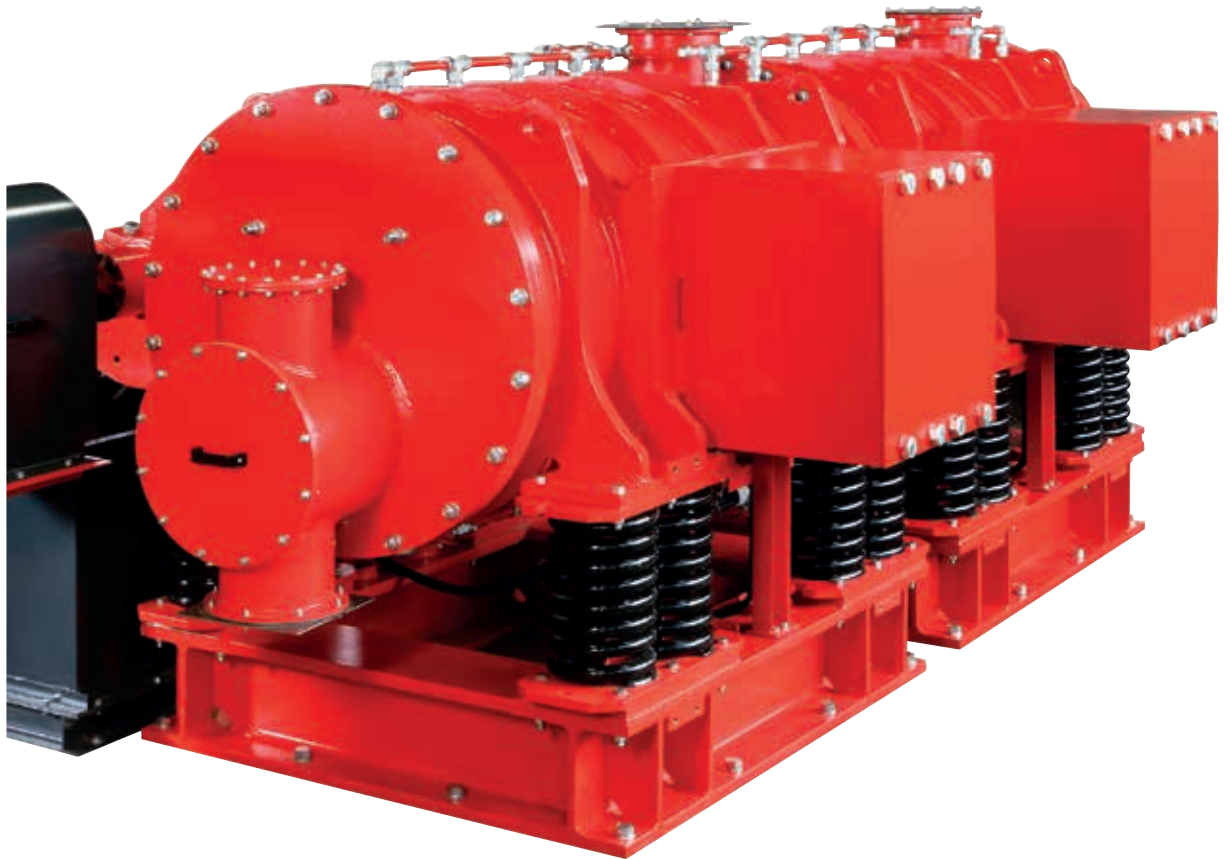

SIEBTECHNIK TEMA



Eccentric vibrating mills

**Mechano-chemical activation and micro-fine milling
of brittle materials of all hardness grades**

The mechanism of action of the eccentric vibrating mill

Only the single-tube eccentric vibrating mill of Siebtechnik GmbH executes, through an exciter unit provided outside, inhomogeneous movements, comprising elliptical, circular and linear vibrations. The upshot is a high degree of loosening of the mill filling with very high impact load on the material to be ground, particularly with large amplitudes. The high specific energy input with a high degree of loosening of the mill filling is a decisive benefit of the single-tube principle, which, caused by the design, also makes a clear reduction in the mill mass and thus in the drive energy possible.

The eccentrically appointed imbalance excitation generates inhomogeneous vibrations, whereby the main wear zone in the eccentric vibrating mill is distributed more uniformly on the bottom half of the plating. With the image "Absolute movement of the grinding bodies in the eccentric vibrating mill", the circulation movement of the grinding-media filling can be discerned, which undertakes transport of the milled material and homogenisation of the milled material.

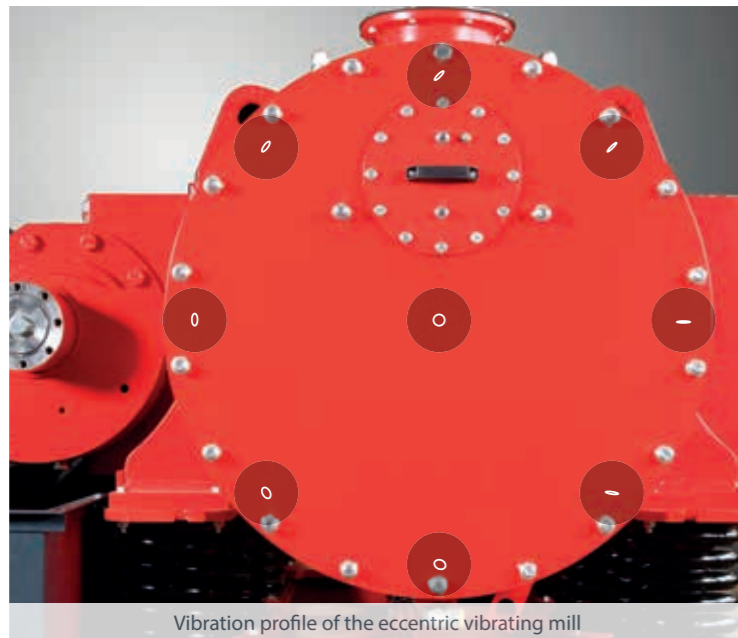

The Siebtechnik eccentric vibrating mill is of modular design and basically comprises

- the cylindrical grinding vessel
- helical springs
- the base frame
- the grinding media
- the exciter unit
- the counter weight

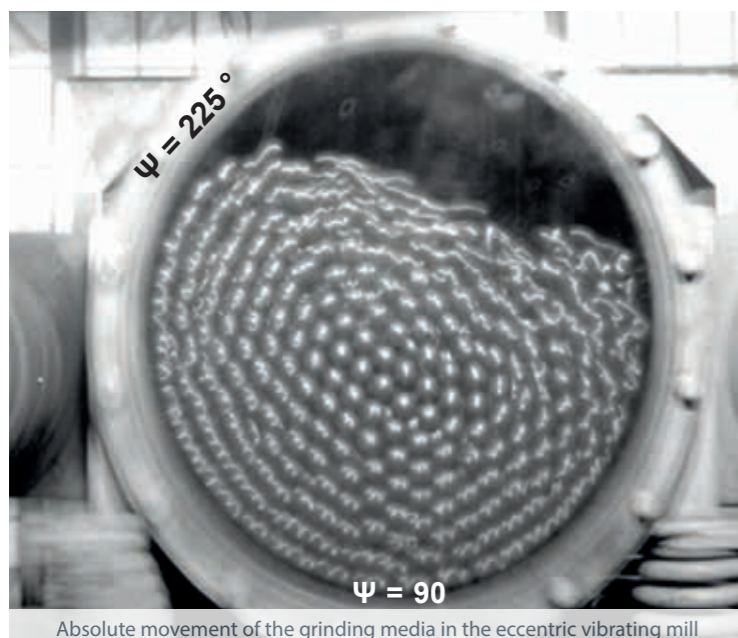

The design and function of the machine

This modular design of the machine offers enormous advantages particularly with larger machines:

- The mill can be split up into small units for transport and installation
- The power train fitted completely on the outside of the mill body is freely accessible once the protective guards have been dismantled
- All drive components and particularly the compact exciter units can be easily exchanged in case of maintenance, whereby downtimes can be considerably reduced compared to circular-oscillating mills
- Furthermore, the grinding vessel modules considerably simplify the change of the grinding media and wear lining
- The grinding vessel modules enable the grinding vessel lengths to be adapted to individual performance requirements or to changed performance requirements in the course of operation

The mill is set – via the direct three-phase drive and the exciter units – into inhomogeneous vibrations, which lead to the already mentioned high energy utilisation. The mill is filled with feed material via a nozzle at the highest point of the grinding vessel and the output at the lowest point at the other end of the grinding vessel. A perforated metal plate in the discharge prevents the grinding media from passing through.

Different output systems enable the ESM to be equipped with the following types of operation.

- Continuous operation
- Batch operation
- Automated batch operation

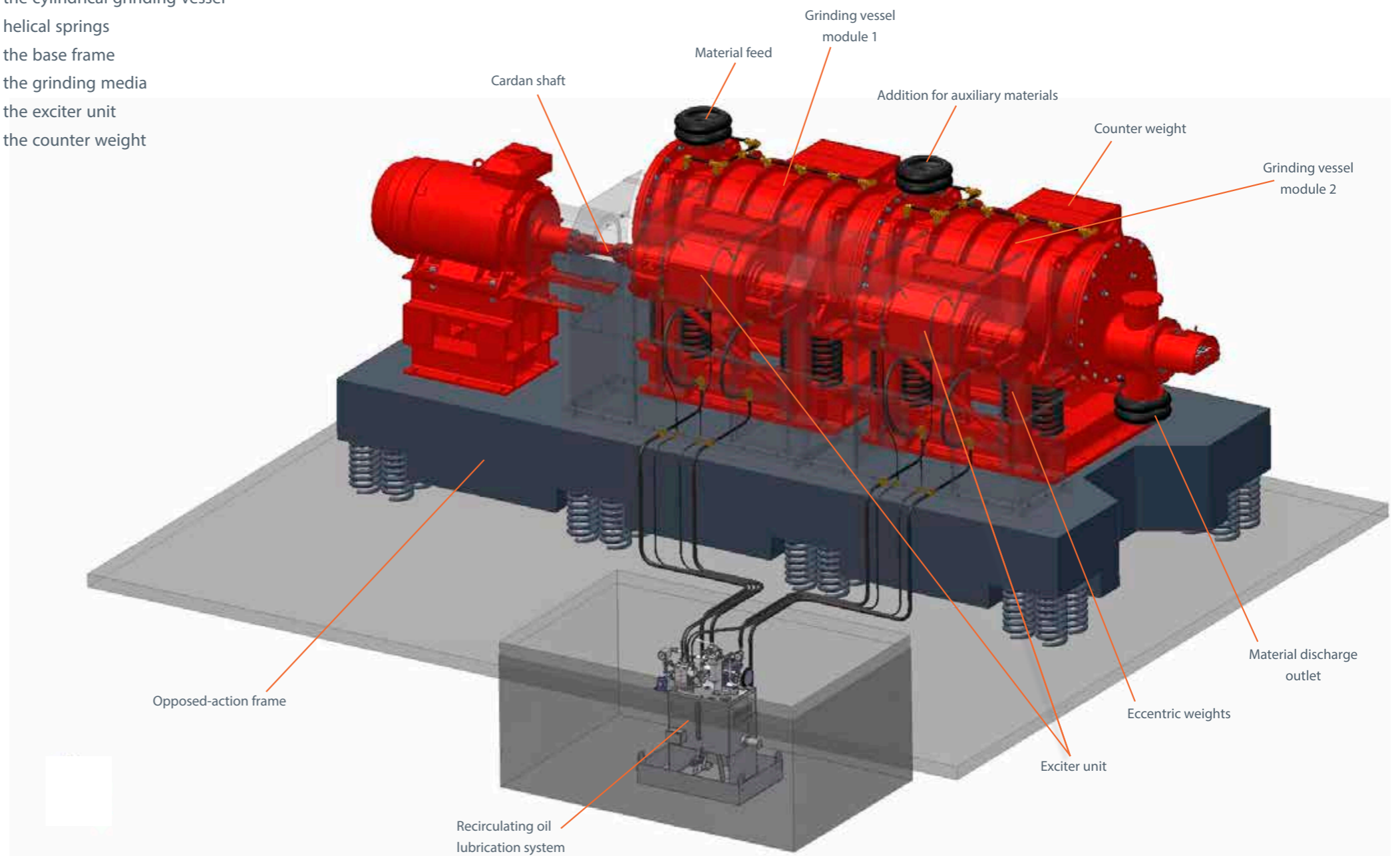

Execution variants

Siebtechnik produces customized eccentric vibrating mills especially for the particular application concerned. Available options include:

- Lining of the grinding vessel with wear-resistant lining made of special steel, ceramic or elastomers
- Grinding-media as balls, rods or Cylpebs in the most varying materials
- Cooling or heating through a double-walled grinding jacket
- Sound absorbing hood
- Opposed-action frame
- Inertisation with protective gas; vacuum; ATEX
- Complete plants including the necessary periphery

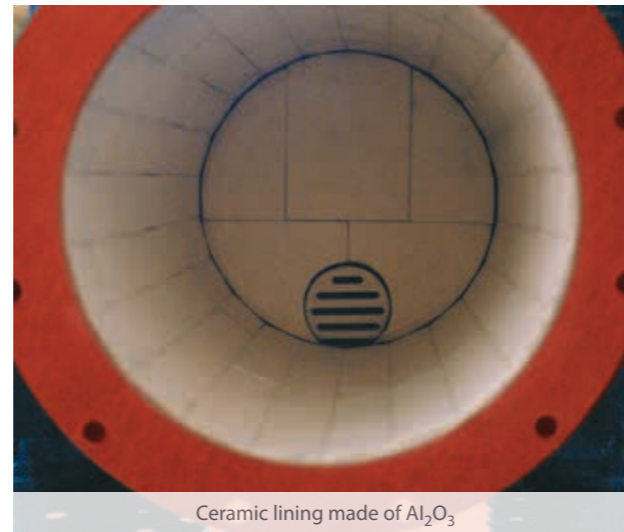

Ceramic lining made of Al_2O_3



ESM 856-2ks and ESM 324-2bs



ESM with sound absorbing hood



ESM 656-0,5bs

Fields of application

The ESM has convincingly proven its performance in the most varied applications and feed materials in the field of mechano-chemical activation and micro-grinding, including in the

- Automotive supply industry
- Pharmaceutical production
- Building industry
- Biomass preparation
- Chemical industry
- Ceramic industry
- Animal food industry
- ...

In mechano-chemical activation, highly reactive conditions are generated, resultant in crystalline systems with impacting load. Generally, brittle materials have a crystalline structure, which prior to comminution represents the lowest-energy condition.

With mechanical load from impact, this crystal structure is partly destroyed and the incorporated energy stored.

This result in highly reactive conditions, which lead, for example, to

- an increase in reactivity,
- an improvement in solubility,
- magnetic properties,
- conductivity
- and other physical properties.

One peculiarity are the reactions of various crystalline systems with each other, whereby through solid-state reactions new materials come about with specific properties. Under these circumstances, the eccentric vibrating mill undertakes the role of a mechano-chemical reactor.

Micro-grinding in the eccentric vibrating mill likewise follows specific principles.

Here, fineness of 0 - 5 μm can be attained depending on the product and grinding duration, and fibrous materials developed.

Plant for the reaction of sulphur with metal powder

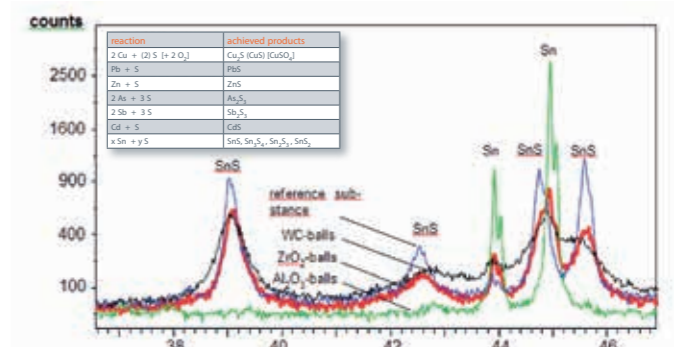
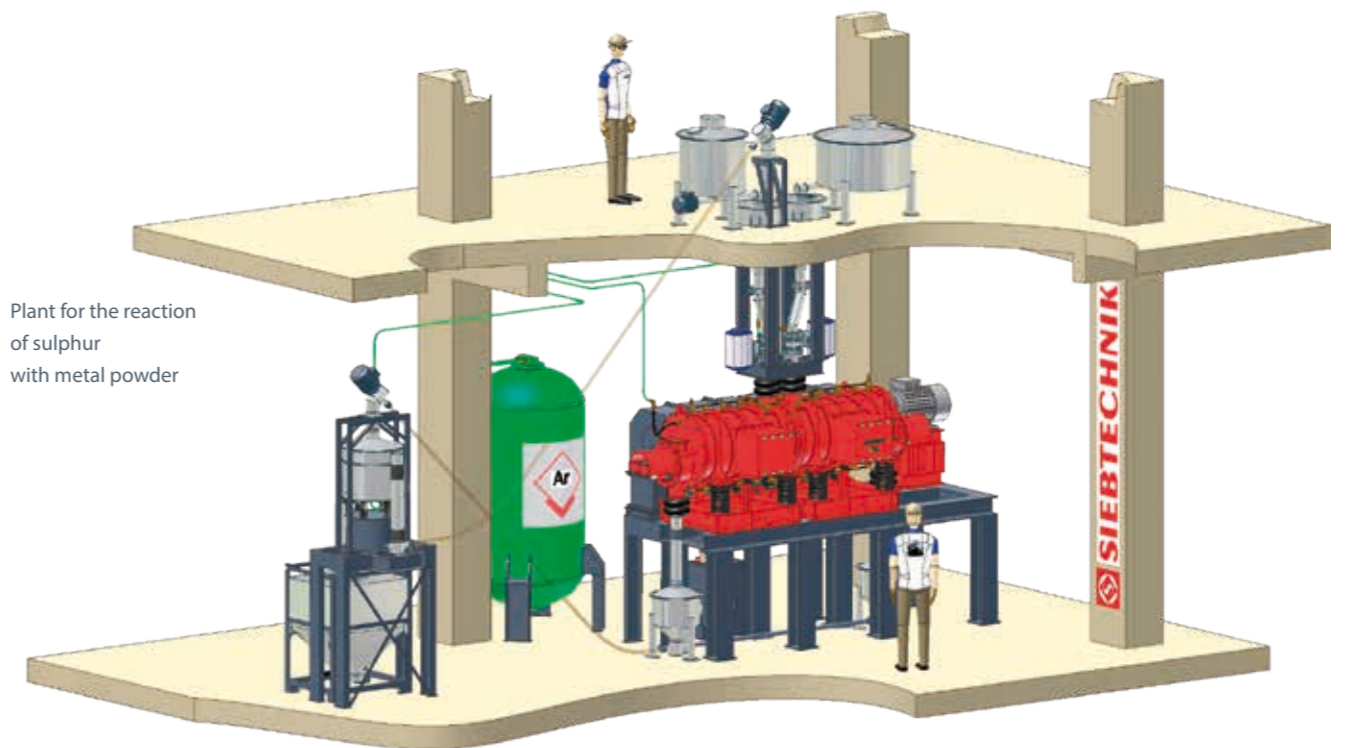

A good example for solid-state reactions generated with the eccentric vibrating mill is the mechano-chemical realisation of metals with sulphur to metal sulphides.

Applications

Fibre destruction of asbestos

As an alternative to thermal asbestos destruction, the eccentric vibrating mill is used for fibre-free micro-comminution of asbestos waste. When asbestos is micro-comminuted with the eccentric vibrating mill, complete destruction of the fibre structure is attained by the impact load and the concomitant high point temperatures through energy dissipation, so that needle-like, fibrous crystal structures are no longer detectable. A fibre-free material is obtained.

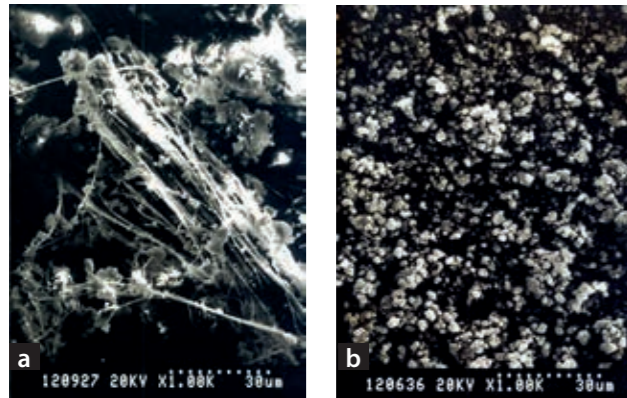

Scanning electron microscopic images of asbestos before (a) and after (b) mechanical transformation

Tungsten carbides

Due to the high impact, the eccentric vibrating mill can also be implemented for the milling of tungsten carbide scrap.

For example, carbide drills or carbide tips can be finely comminuted.

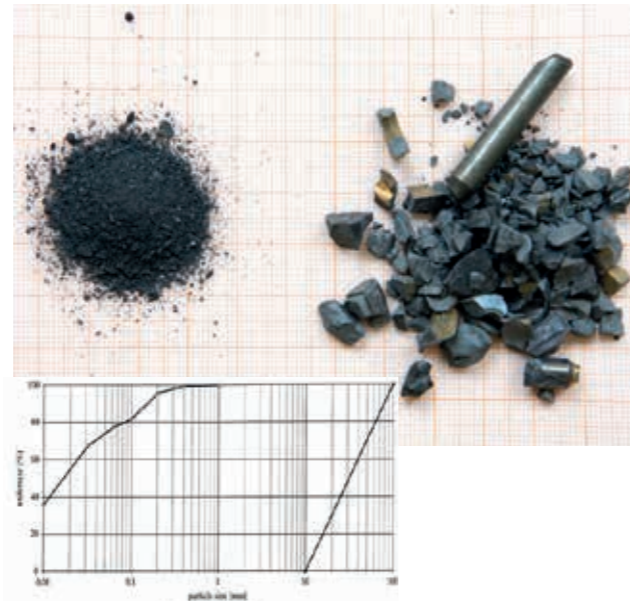

Grinding experiments in the Siebtechnik Technical Centre

For product tests and grinding experiments in the Siebtechnik Technical Centre testing machines of varied design are available with the pertinent technical equipment for designing the mill sizes for the particular performance requirements concerned.

All machines from the Technical Centre can also be made available as rental machines, so that specific grinding problems can also be tested on the spot over a protracted period of time.

Technical data

ESM 32 4 - 1 k s

Key for designation of the eccentric vibrating mill

Grinding vessel lining (s: steel, k: ceramic, g: rubberised)

Operational mode (k: continuous, b: batch – discontinuous)

Number of modules

Pole number of the drive motor (4: 1,500 rpm, 6: 1,000 rpm)

Diameter characteristic factor of the grinding tube in cm

Machine description: Eccentric vibrating mill

ESM	module	194		234		324		504		654		756		856	
		1	1	1	2	1	2	1	2	1	2	1	2		
Total content of the grinding vessel	l	11	19	53	106	219	438	376	752	605	1210	951	1902		
Grinding-media content	l	9	15	42	84	175	350	301	602	484	968	761	1522		
Weight steel grinding-media	kg	43	76	190	380	830	1660	1400	2800	2250	4500	3530	7060		
Weight mill (without grinding-media)	kg	141	140	550	1100	1700	3400	2600	5200	5300	10600	8500	17000		
Motor output	kW	0,55	1,1	5,5	11	18,5	37	30	55	45	90	75	160		
Dimensions	D _M inside	mm	174	235	307	476	620	712	820						
	L _M	mm	450	450	712	1232	1246	1520	1800						
	L1-modular	mm	750	1400	1950	2450	2550	3100	4050						
	L2-modular	mm	-	-	2750	3800	3850	4700	5900						
	L	mm	650	800	1250	1450	1650	1850	2250						
Oscillating circuit diameter		6 - 8 mm	at 1,500 rpm of the motor (Types with KPI .4)												
		12 - 13 mm	at 1,000 rpm of the motor (Types with KPI .6)												

Subject to technical alterations

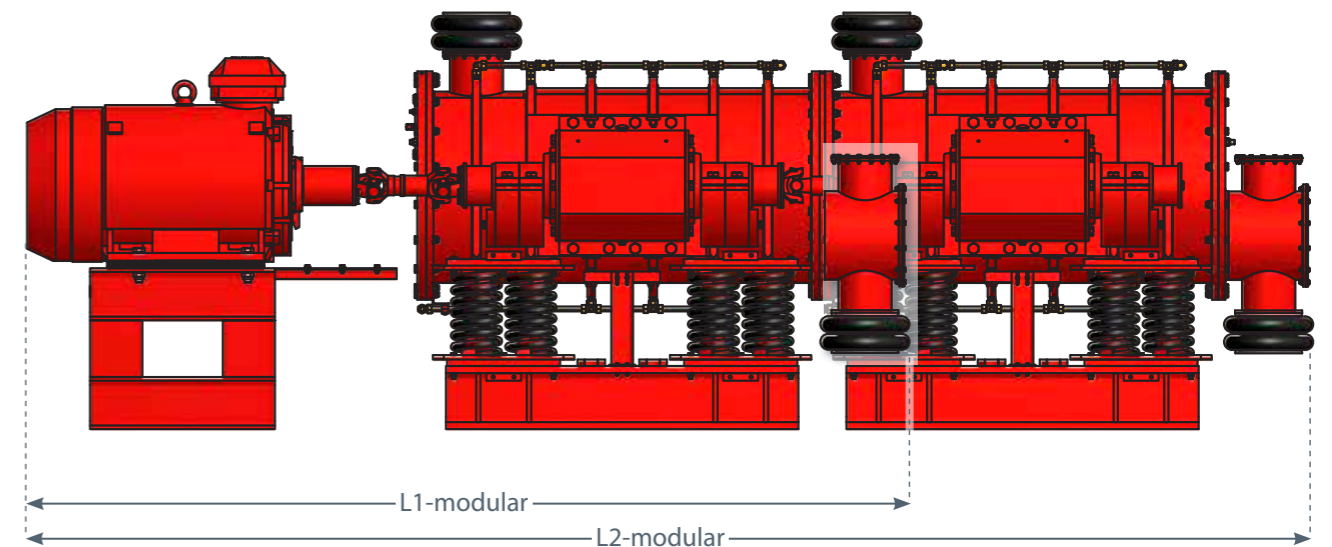

One Solution. Worldwide.

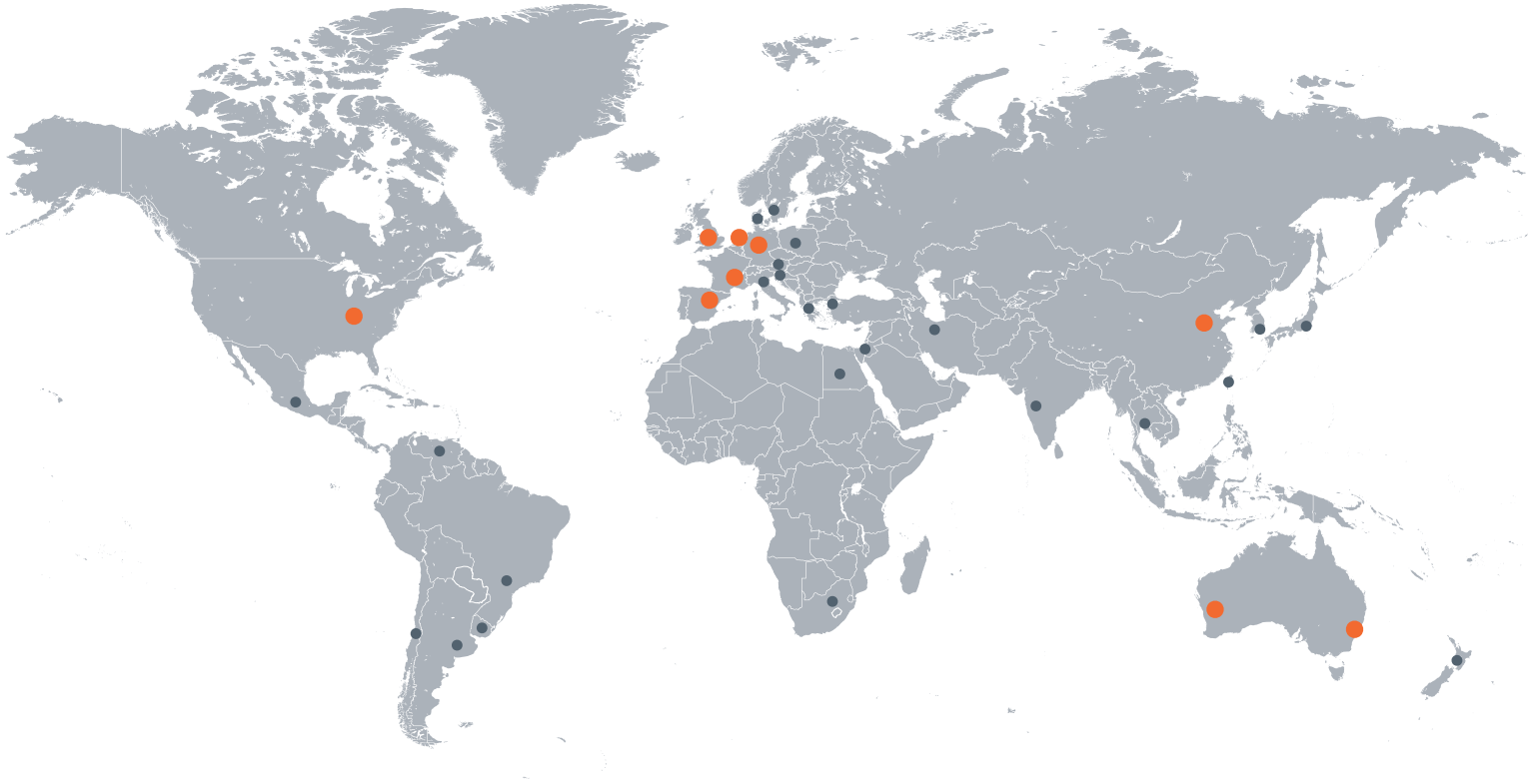

SIEBTECHNIK TEMA provides more than 50 local support offices worldwide as well as main sites located in:

Mülheim an der Ruhr, Germany | Rijswijk / The Hague, The Netherlands | Madrid, Spain
Daventry, Great Britain | Mundolsheim, France | Sydney & Perth, Australia | Cincinnati, USA
Tianjin, China

We are experts in the field of solid-liquid separation and the processing of bulk materials

Automation | Channel conveyors | Crushing & Milling Equipment | Control Screening Machines
Decanter | Dryers | Laboratory Equipment | Pneumatic Tube Systems | Preparation Systems
Process Equipment | Pulsator Jigs | Pusher Centrifuges | Sampling Systems | Screening
Machines | Screen Worm Centrifuges | Sliding Centrifuges | Vibrating Centrifuges

Copyright information: All drawings, images and registered trademarks in this document are protected by copyright. Any reproduction or partial use without the explicit permission of us as copyright and trademark owner is prohibited. Violations of copyright or trademarks will be legally pursued.